

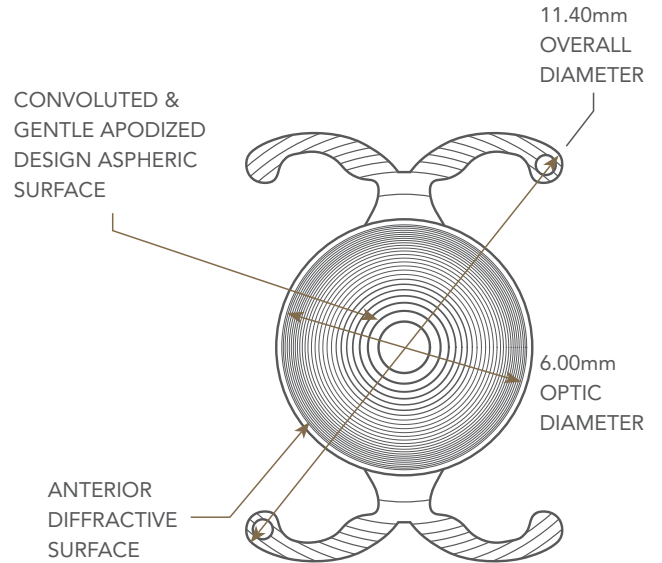

FINEVISION® HP

Trifocal Hydrophobic

Description



Model	POD F GF	
Material	GFY Hydrophobic Acrylic ¹	
Overall diameter	0.45 inches (11.40mm)	
Optic diameter	0.24 inches (6.00mm)	
Optic	Biconvex Aspheric Trifocal	
Haptic design	Double C-loop with Ridgetech® & Posterior 5° Angulated Haptic	
Filtration	UV & Selective Blue Light Filter (~400-450nm)	
Refractive index	1.53	
Abbe number	42	
Additional power (IOL plane)	+1.75D & +3.50D	
Injection system	Medicel Accuject 2.1	
Spherical power	+10D to +30D (0.5D steps)	
Suggested A constant ²		Interferometry
	SRK/T: A	119.5

¹ The PhysIOL GFY® is patented since 2010.

² Values estimated only; surgeons are recommended to personalize their A-constant based on their surgical techniques and equipment, experience with the lens model and postoperative results.

Product Information

Manufacturer	PhysIOL s.a. - Liège Science Park Allée des Noisetiers 4 B-4031 Belgium +32 4 361 05 49 physiol@bvimedical.com
Certificate information	CE (EU) 2017/745, Annex IX Chapter II : MDR 735726 R000 QMS (EU) 2017/745, Annex IX Chapter I and III : MDR 735719 R000 ISO 13485:2016 & EN ISO 13485:2016 : MD 658518 ISO 13485:2016 : MDSAP 691544 FDA Number: P240038
Shelf life	Five (5) years from manufacturing date
Intended purpose	The posterior chamber intraocular lens is intended to be placed into the capsular bag with an anterior capsulorhexis for the replacement of the human lens to achieve the visual correction of aphakia in adult patients in whom the cataractous lens has been removed.
Indication for use	The lens should be used as intended in adult patients surgically treated for cataract, with possibly associated presbyopia, who desire improved uncorrected far vision, useful near and intermediate visual functions and reduced spectacle dependence.
Product Composition	No products of animal or human origin are present in the implant. The intraocular lens is 100% composed of the covalently crosslinked proprietary material of medical quality (GFY), which is a (2-hydroxyethylmethacrylate; phenoxy ethylacrylate; polypropylene glycol dimethacrylate) copolymer, including a UV and a blue light-filtering chromophores covalently bound to the material.
For sterile product	All IOLs from PhysIOL are steam sterilized
Packaging Material	Holder (Polypropylene) Container (Polypropylene) Storage liquid (0.9% NaCl solution) Aluminium lid (Aluminium Gold) Container label (paper) Blister PP (Polypropylene) Tyvek lid
Product Class	Classified as Class IIb implantable long-term surgically invasive medical devices under Rule 8 of Annex VIII of the MDR 2017/745.

